

CITY OF BELLEMEADE, KY
ORDINANCE # 2021-08

AN ORDINANCE OF THE CITY OF BELLEMEADE, KENTUCKY REGULATING FRONT YARD FENCING

WHEREAS, the City of Bellemeade and the Commission of the City of Bellemeade are authorized to adopt ordinances and resolutions necessary for the exercise of its powers and prescribe penalties for the violation of ordinances in accordance with law; and

WHEREAS, the City of Bellemeade deems it to be in the best interests of the citizens of Bellemeade that Front Yard Fencing be restricted;

NOW THEREFORE, BE IT ORDAINED, and IT HEREBY IS ORDAINED, pursuant to Kentucky law and the powers vested in the City, that the Bellemeade Front Yard Fencing Ordinance is adopted as follows:

The Bellemeade Code of Ordinances will contain a new section 80 Entitled "Front Yard Fencing Prohibited" and it will read as follows:

§80.01 Front Yard Fencing Prohibited

- A. Fencing is prohibited in all Front Yards unless the fence meets the definition of a Decorative Feature.
- B. Fences constructed prior to November 8, 2021 are not subject to this ordinance.

§80.02 Definitions

Decorative Feature: Shall mean any fence no more than 30 inches high and no more than 14 ft in length, so long as it is not intended for the purpose of preventing persons and/or animals, from crawling or passing through the fence except at established gateways. A Decorative Feature shall not include a fence constructed of chain link material or any other type of woven fence. By way of example only, an unenclosed fence corner as diagramed below would be considered a Decorative Feature.

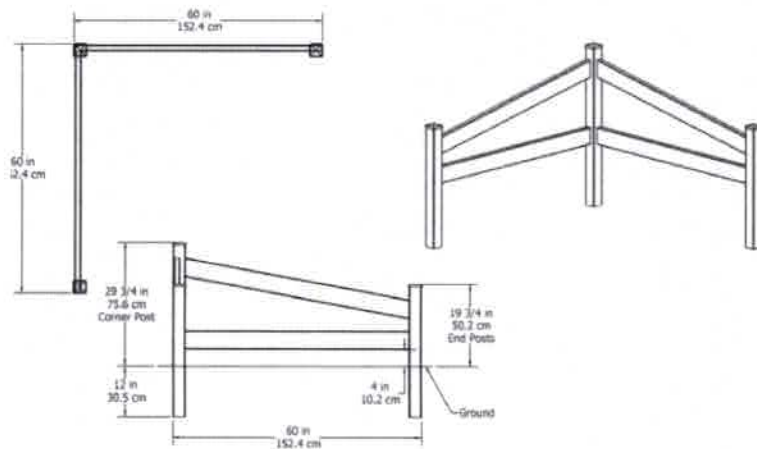

Fence: A structure serving as an enclosure, barrier or boundary including but not limited to posts, boards, wire, vinyl, or gates. Shrubs or bushes which form a barrier or boundary are considered fences. However, "Fence" as used in this ordinance shall not include a "Decorative Feature."

Front yard. An open, unoccupied space on a lot facing a street and extending from the front of the lot to the front of the principal building, between the side lot lines.

Rear yard. A space unoccupied by the principal structure extending for the full width of the lot between a principal structure and the rear lot line.

Side yard. An open unoccupied space on the same lot with the building, situated between the building and the side line of the lot, and extending from the front yard to the rear yard.

§80.03 Penalty

Any person found to be in violation of this chapter shall be subjected to a fine of not less than \$50 nor more than \$500 for each offense, plus the cost to the city for removal of that fence. Each 24-hour period during which a fence stands in violation of this chapter shall constitute a separate offense. This chapter is subject to enforcement by the Commissioner for Public Works or Public Lands.

First Reading the 8th day of November , 2021.

Second Reading passed and approved this 13th day of December, 2021.

All those voting in favor:

JAMES MARTIN
HAUK BRUMLEVE
BEN ZICKEL
SANDY WALKER
UNANIMOUS



Patricia Scott, City Clerk



James N. Martin, Mayor